

PCIE-9452

PICMG 1.3 Socket M Intel® Core™2 Duo CPU Card With VGA, Dual PCIe GbE, SATA II and USB 2.0

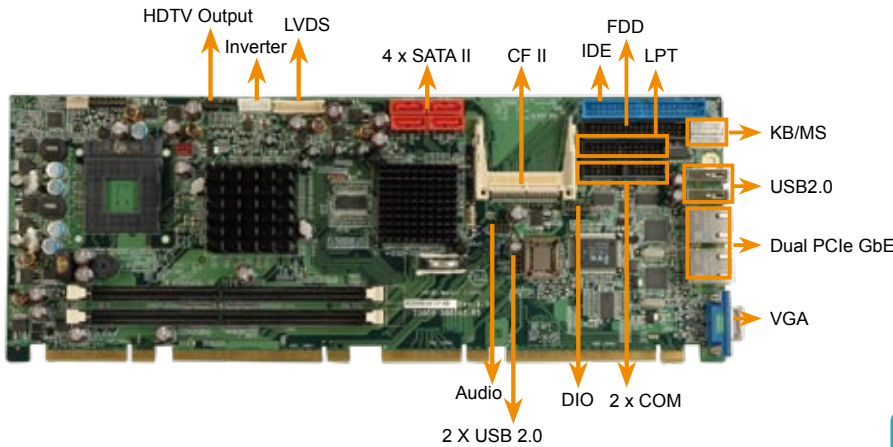

Intel® Matrix Storage Manager

Dual DDR II
667

FSB 667

Socket M



Specifications

- ◆ **CPU**
Socket M Intel® Core™2 Duo, Core Duo/Solo, with 667MHz FSB
Intel® Celeron M 533MHz FSB (Yonah Core)
- ◆ **System Chipset**
Intel® 945GM + ICH7R
- ◆ **BIOS**
AMI Flash BIOS
- ◆ **System Memory**
2 x 240-pin dual channel DDRII 400/533/667MHz up to 4GB
- ◆ **Ethernet**
Dual PCIe GbE Broadcom BCM5787M chipsets
- ◆ **I/O Interface**
2 x RS-232
1 x LPT
8 x USB 2.0
(2 by Pin header(CPU Board) + 2 by bracket + 4 by Pin header(backplane))
4 x SATA II with Intel RAID 0,1,5 and 10
1 x IDE
1 x FDD
1 x KB (by pin header)
1 x MS (by pin header)
- ◆ **Digital I/O**
8-bit digital I/O, 4-bit input/ 4-bit output
- ◆ **IrDA**
1 x IrDA by pin header
- ◆ **Super I/O**
ITE IT8712F
- ◆ **Display Interface**
VGA / 18-bit dual channel LVDS integrated in Intel 945GM
Support HDTV resolution up to 1080i / 1080P by component interface
- ◆ **Audio**
5.1 channel AC'97 Audio Kit with Realtek ALC655 codec
7.1 channel HD Audio Kit with Realtek ALC883 support dual audio streams
- ◆ **SSD**
CF Type II
- ◆ **Watchdog Timer**
Software programmable supports 1 ~255 sec. System reset
- ◆ **Power Supply**
ATX Power
- ◆ **Power consumption**
5V@4.14A, 12V@2.9A, 3.3V@ 0.72A
(Intel® Core™2 Duo T7200 2.06GHz/667 MHz CPU with 1GB DDRII 667MHz)
- ◆ **Temperature**
operation: 0°C ~ 60°C (32 ~ 140°F)
- ◆ **Humidity**
operation: 5% ~95% non-condensing
- ◆ **Dimensions**
338 mm x 126 mm
- ◆ **Weight**
GW: 1100 g / NW: 380 g

Features

1. PICMG1.3 and RoHS compliant
2. Socket M Intel® Core™2 Duo CPU with 667MHz FSB
3. Dual channel DDRII 400/533/677 MHz support up to 4GB
4. High performance PCI Express Gigabit Ethernet controller
5. 4 x SATA II with Intel Matrix Mstorage Manager support

Packing List

1 x PCIE-9452 Single Board Computer
1 x Mini Jumper Pack
1 x ATA 66/100 flat cable (P/N: 32200-000052-RS)
4 x SATA cable (P/N: 32000-0628000-RS)
2 x SATA Power cable (P/N: 32100-0886000-RS)
1 x Dual RS-232 cable (P/N: 19800-000051-RS)
1 x USB cable (P/N: CB-USB02-RS)
1 x KB/MS cable with bracket (P/N: 19800-000066-RS)
1 x Utility CD
1 x QIG

Ordering Information

Part No.	Description
PCIE-9452-R10	PICMG 1.3 Socket M Intel® Core™2 Duo CPU Card With VGA, Dual PCIe GbE, SATA II and USB 2.0
AC-KIT-883HD-R10	7.1 Channel HD Audio Kit with Realtek ALC883 support dual audio streams
AC-KIT08R-R10	5.1 Channel AC'97 Audio Kit with Realtek ALC655
CF-479B-RS	CPU cooler
SDVO-100VGA-R10	PCIe x16 VGA Output SDVO Card supports dual display (IEI CPU board only)
SDVO-100DVI-R10	PCIe x16 DVI Output SDVO Card supports dual display (IEI CPU board only)
32000-000066-RS	Dual Mini DIN cable with bracket for KB/MS
19800-000049-RS	LPT cable
32200-000017-RS	FDD cable