

**EPIC Intel® Pentium® M/Celeron® M CPU with
VGA/LVDS, SATA, LAN and Audio**

NANO-8522

Quick Installation Guide

Version 1.2

Aug. 31, 2007

Package Contents

NANO-8522 package includes the following items:

- 1 x NANO-8522 single board computer
- 1 x IDE flat cable 44p/44p
- 1 x KB/MS Y cable
- 1 x Audio cable
- 2 x SATA cable
- 1 x SATA Power cable
- 1 x Power cable
- 2 x RS-232 cable
- 1 x mini jumper pack
- 1 x Utility CD
- 1 x QIG (Quick Installation Guide)



©2006 Copyright by IEI Technology corp.
All rights reserved.

Specifications

- CPU: Intel® Celeron® M 600MHz 512K cache / 1.0GHz zero cache processor
(Socket 479 Intel® Pentium® M,Celeron® M 400MHz FSB(Banias core) up to 2.10GHz)
- System Chipset: Intel 852GM+ICH4
- BIOS: AMI BIOS
- System memory: 1x 200-Pin SO-DIMM DDR 266MHz up to 1GB
- Ethernet
Intel® 82541PI GbE chipset with ASF2.0 remote control support
Intel® 82551ER Ethernet chipset
- I/O
I/O Interface:
2 x SATA with ALI M5283 RAID 0,1 function support
6 x USB 2.0
1 x CF Type II
3 x RS-232
1 x RS-232/422/485
1 x PS/2 KB/MS
1 x IDE
- Expansions: 1 x PC-104(PCI bus)
- Audio: Realtek ALC655 with AC'97 codec
- Digital I/O: 8-bit digitl I/O,4-bit input/ 4-bit output by super I/O
- IrDA: By super I/O
- Super I/O: W83627EHG
- Display Interface:
VGA integrated in Intel® 852GM
18-bit dual channel LVDS
- Watchdog timer
Software programmable supports 1~255 sec. system reset
- Power Supply: +12V only, AT/ATX support

- Power Consumption:
12V@0.96A
(ULV Intel®Celeron® M 800MHz zero cache with DDR 266 MHZ,256 MB RAM)
12V@1.99A
(Pentium M 1.7GHz/L2-2M withDDR266MHz,512MB RAM)
- Humidity: Operation: 5% ~ 95%, non-condensing
- Temperature: 0 ~ 60°C(32 ~ 140°F)
- Dimension: 165 mm x 115 mm
- Weight: GW: 1100g; NW: 250g

Ordering Information

NANO-8522E-1GZ-R12

EPIC SBC with Intel® Celeron® M 1GHz zero cache processor on board with VGA/LVDS, LAN, SATA and Audio

NANO-8522E-600Z-R12

EPIC SBC Intel® Celeron® M 600MHz 512K cache processor on board with VGA/LVDS, LAN, SATA and Audio

NANO-8522G-R12

EPIC SBC Socket 479 Intel® Pentium® M/Celeron® M(Banias core/90nm) Processor FSB400MHz, VGA/LVDS, GbE, SATA and Audio

CF-479B-RS: CPU Cooler

32000-070300-RS: USB cable

32200-015100-RS: LPT cable

32200-026500-RS: RS-232/422/485 cable

32100-052100-RS: ATX Power Cable

Jumpers setting and Connectors

JP1: Compact Flash Master / Slave Selector	
JP1	DESCRIPTION
NONE	Slave
1-2	Master

JP2: Com2 RS232 / RS422 / RS485 Selector	
JP2	DESCRIPTION
1-2	RS-232
3-4	RS-422
5-6	RS-485

JP4: Clear CMOS Setup (Reserve Function)	
JP4	DESCRIPTION
1-2	Normal Operation
2-3	Clear CMOS Setup

JP5: PC104+ SERIRQ net to CN3 pin B1 Selector	
JP5	DESCRIPTION
NONE	Disconnect
3-4	Connect

JP6: LCD Voltage Selector (LVDS1 pin27~30)	
JP6	DESCRIPTION
1-2	LCDVCC = +3.3V
2-3	LCDVCC = +5V

BT1: Battery Connector	
JP6	DESCRIPTION
1-2	BAT+
2-3	GND

AUDIO: Audio connector (Box-header 5x2 2.0mm)			
Pin	Description	Pin	Description
1	LINE_OUT-R	2	LINE_IN-R
3	GND	4	GND
5	LINE_OUT-L	6	LINE_IN-L
7	GND	8	GND
9	MIC-IN	10	NC

DIO1:4 BIT GPIO Connector			
Pin	Description	Pin	Description
1	GND	2	VCC
3	OUT0	4	OUT1
5	OUT2	6	OUT3
7	IN0	8	IN1
9	IN2	10	IN3

CN4:12V input Connector			
Pin	Description	Pin	Description
2	GND	4	VCC12
1	GND	3	VCC12

CN5: LED Connector	
Pin	Description
1	+5V
2	GND
3	VCC5 LED+
4	GND
5	HDD LED+
6	HDD LED-

CN6: Compact Flash Connector(Secondary IDE)			
Pin	Description	Pin	Description
1	GROUND	26	VCC-IN CHECK1
2	DATA3	27	DATA11
3	DATA4	28	DATA12
4	DATA5	29	DATA13
5	DATA6	30	DATA14
6	DATA7	31	DATA15
7	HDC_CS0#	32	HDC_CS1
8	N/C	33	N/C
9	GROUND	34	IOR#
10	N/C	35	IOW#
11	N/C	36	N/C
12	N/C	37	INTERRUPT
13	VCC_COM	38	VCC_COM
14	N/C	39	CSEL
15	N/C	40	N/C
16	N/C	41	HDD_RESET
17	N/C	42	IORDY
18	SA2	43	N/C
19	SA1	44	VCC_COM
20	SA0	45	HDD_ACTIVE#
21	DATA0	46	N/C
22	DATA1	47	DATA8
23	DATA2	48	DATA9
24	N/C	49	DATA10
25	VCC-IN CHECK2	50	GROUND

COM2: Serial Port2 connector (Pin-header 7x2 2.0mm)			
Pin	Description	Pin	Description
1	DCD#	2	DSR#
3	RxD	4	RTS#
5	TxD	6	CTS#
7	DTR#	8	RI#
9	GND	10	GND
11	TxD485+	12	TxD485-
13	RxD485+	14	RxD485-

COM3: Serial Port3 Connector (Pin-header 5x2 2.0mm)			
Pin	Description	Pin	Description
1	DCD#	2	DSR#
3	RX	4	RTS#
5	TX	6	CTS#
7	DTR#	8	RI#
9	GND	10	GND

COM4: Serial Port4 Connector (Pin-header 5x2 2.0mm)			
Pin	Description	Pin	Description
1	DCD#	2	DSR#
3	RX	4	RTS#
5	TX	6	CTS#
7	DTR#	8	RI#
9	GND	10	GND

KBMS1: 6-pin header Keyboard & Mouse Connector	
Pin	Description
1	VCC5
2	MOUSE DATA
3	MOUSE CLOCK
4	KEYBOARD DATA
5	KEYBOARD CLOCK
6	GND

FAN1: CPU fan	
Pin	Description
1	Fan Speed Detect
2	+12V
3	GND

J2: ATX Power connector	
Pin	Description
1	5VSB
2	GROUND
3	PSON

LPT1: Parallel Port Connector			
Pin	Description	Pin	Description
1	STROBE#	14	AUTO FORM FEED #
2	DATA 0	15	ERROR#
3	DATA 1	16	INITIALIZE
4	DATA 2	17	PRINTER SELECT LN#
5	DATA 3	18	GROUND
6	DATA 4	19	GROUND
7	DATA 5	20	GROUND
8	DATA 6	21	GROUND
9	DATA 7	22	GROUND
10	ACKNOWLEDGE	23	GROUND
11	BUSY	24	GROUND
12	PAPER EMPTY	25	GROUND
13	PRINTER SELECT	26	N/C

Ir1: IrDa Connector	
Pin	Description
1	VCC5
2	N/C
3	IrRxD
4	GROUND
5	IrTxD

CN1: LCD Inverter Connector	
Pin	Description
1	LCD_BKLTCTL
2	GROUND
3	VCC12
4	GROUND
5	LCD_BKLEN

LVDS1: LCD Interface Connector – support LVDS 18 BIT 2 CH			
Pin	Description	Pin	Description
2	GND	1	GND
4	AY0-	3	AY0+
6	AY1-	5	AY1+
8	AY2-	7	AY2+
10	AYCLK-	9	AYCLK+
12	AY3-	11	AY3+
14	GND	13	GND
16	BY0-	15	BY0+
18	BY1-	17	BY1+
20	BY2-	19	BY2+
22	BYCLK-	21	BYCLK+
24	BY3-	23	BY3+
26	GND	25	GND
28	LCDVCC	27	LCDVCC
30	LCDVCC	29	LCDVCC

PWRON: ATX POWER BUTTON Connector	
Pin	Description
1	Button 1(GND)
2	Button 2(VCC)

RST1: Reset Connector	
Pin	Description
1	Reset 1(3.3V)
2	Reset 2(GND)

Board Layout: Jumper and Connector Locations

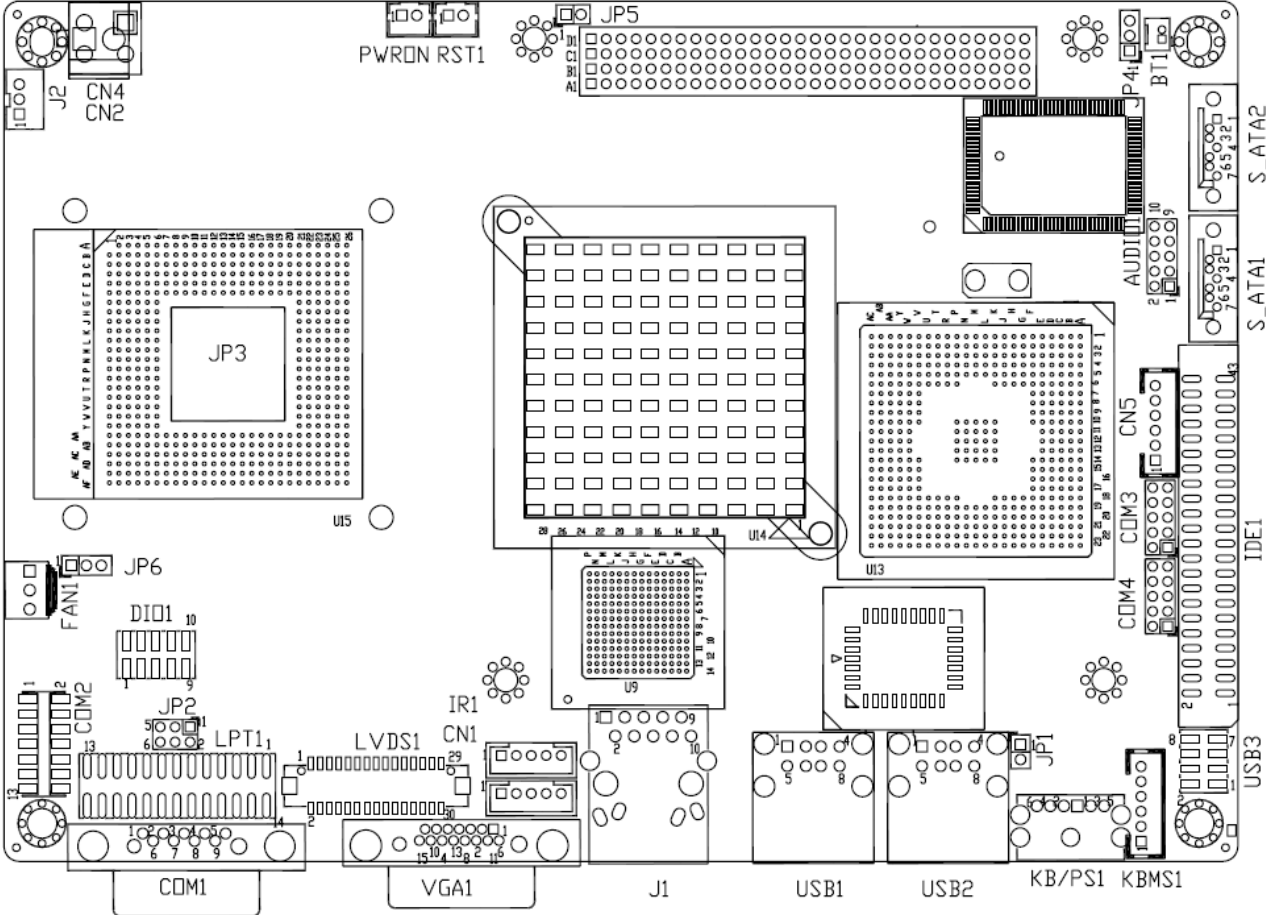

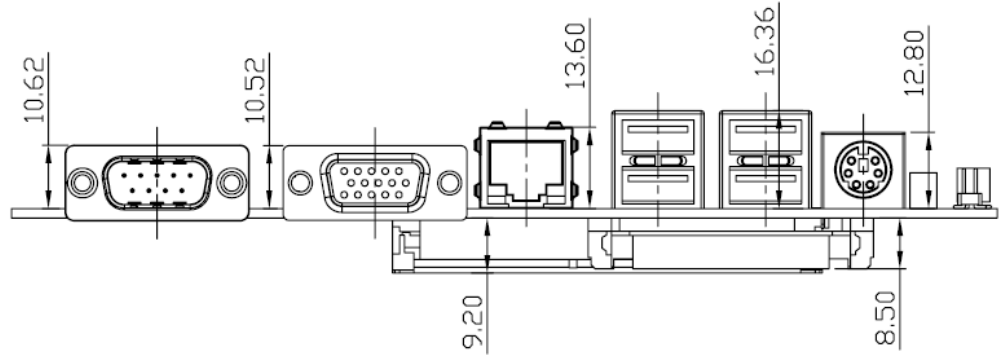
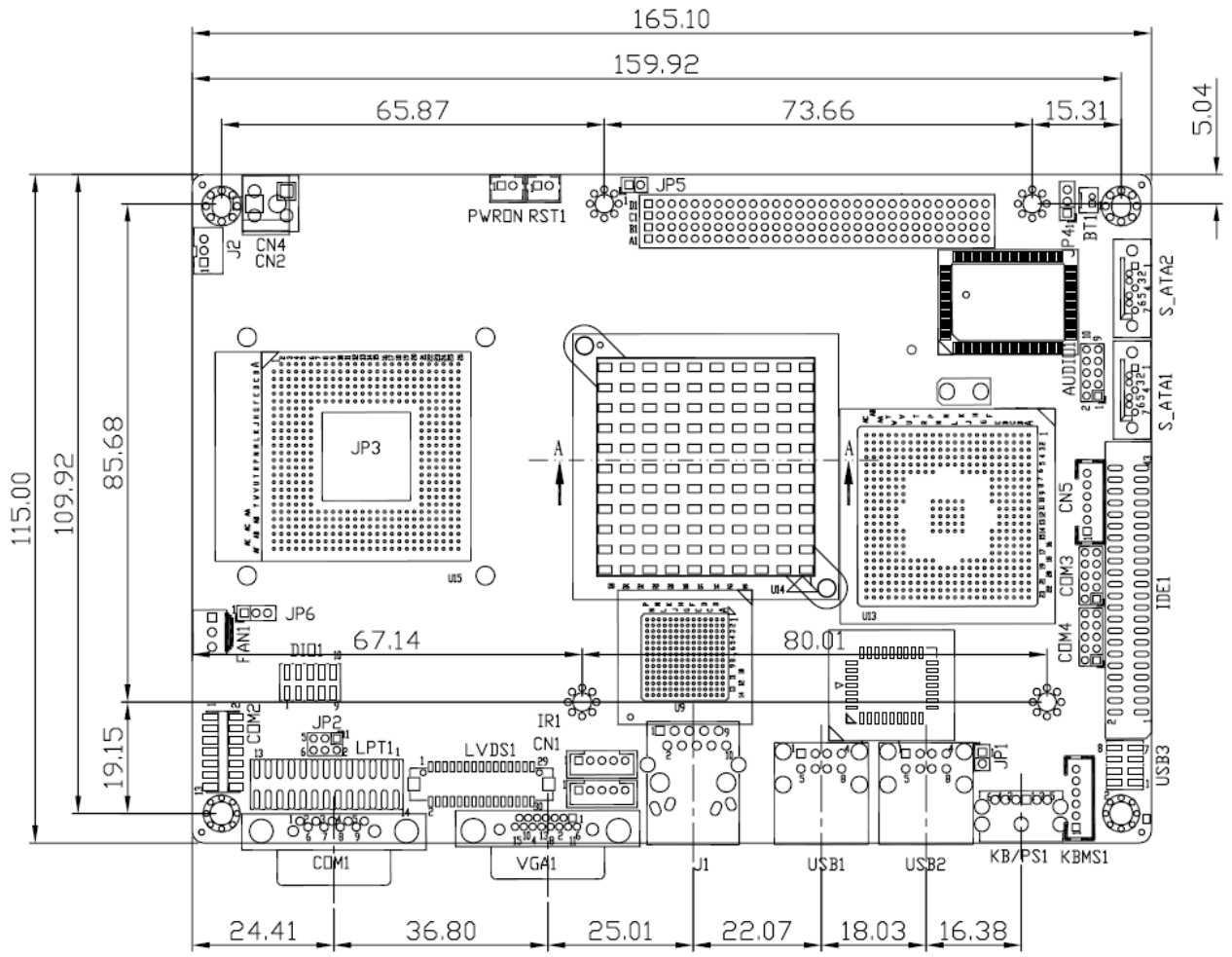

U14 Heat Sink Height

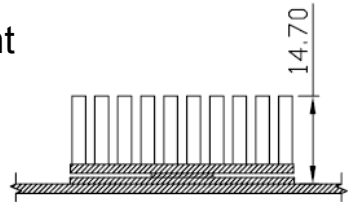

Section A